

Totaline® Electronic Air Cleaners

P102-12, P102-14A, P102-14B, P102-20



Description

- The Totaline High Efficiency Electronic Air Cleaner has been designed to remove atmospheric and household dust, coal dust, insecticide dust, mites, pollen, mold spores, fungi, bacteria, viruses, pet dander, cooking smoke and grease, tobacco smoke particles, and more down to 0.01 micron (0.01 micron = 1/2,540,000 of an inch).
- Contains a lifetime filter that is environmentally friendly and preferable to disposable filters.
- User-friendly. Easy to maintain.
- Ideal for homes with allergy, asthma or respiratory sufferers, smokers, pets, cooking odors, and mustiness.
- Helps protect and prolong the operating efficiency of the heating and cooling equipment.

Standard Features

- Prefilters (2) are constructed of aluminum mesh, to prevent lint and large particles from entering the collecting cells.
- Collecting Cells (2) are constructed of heavy gauge aluminum for durability and ease of maintenance. Cell guides ensure proper placement of collecting cells in cabinet.
- Activated Carbon Filters (C) help remove unpleasant odors (optional).
- Solid State Power Board is manufactured on-site for high reliability and long life. Uniquely equipped with a variable resistor (potentiometer) to adjust high voltage output. Output has been preset for optimum efficiency, however, as voltage may vary in extreme conditions of dryness, humidity or proximity to hydro towers, raising or lowering potentiometer allows for proper voltage output.

Standard Features

- Electronic Air Proving Switch (AS) allows for quick wiring. Automatically cycles Air Cleaner on/off with the system fan.
- Lighted ON/OFF Switch (Orange) shows power to the Air Cleaner.
- Performance Indicator Light (Green LED) indicates high voltage to the collecting cells, ensuring air cleaner is operating properly at a glance.

Cabinet Construction Features

- Heavy gauge galvanized steel cabinet resists corrosion and provides trouble-free vertical or horizontal installation. Holes are provided to facilitate mounting to the duct work or air handling system.
- Durable powder coat paint finish on door and top lid resists corrosion.
- Power Box is removable. Contains the ON/OFF switch, performance indicator light, safety interlock switch, high voltage power board and the air proving switch.

Accessories

- DAX Air Cleaner Detergent simplifies the washing process by quickly and safely removing contaminants from filters.
32 oz. (1 L) Spray Bottle, Part #9900
- Activated Carbon Filters (3 per pack). Replace every 3-4 months. For Models:
P102-12, P102-14A Part #P102-1156
P102-14B, P102-20 Part #P102-1856

Warranty

- Five Year Limited Parts.



Totaline® Electronic Air Cleaners

P102-12, P102-14A, P102-14B, P102-20

SPECIFICATIONS

MODEL	P102-12	P102-14A	P102-14B	P102-20
House Size	<2400 ft ² <222.96 m ²	<3000 ft ² <278.70 m ²	<3000 ft ² <278.70 m ²	>3000 ft ² >278.70 m ²
Air Flow	up to 1200 cfm up to 2039 m ³ /hr	up to 1400 cfm up to 2379 m ³ /hr	up to 1400 cfm up to 2379 m ³ /hr	up to 2000 cfm up to 3398 m ³ /hr
Duct Size	16 x 20 in 40.5 x 51 cm	16 x 25 in 40.5 x 63.5 cm	20 x 20 in 51 x 51 cm	20 x 25 in 51 x 63.5 cm
Weight	28 lbs 12.9 kg	30 lbs 13.5 kg	33 lbs 15.3 kg	38 lbs 17.5 kg
Power	120 v 60 hz 30 watts	120 v 60 hz 30 watts	120 v 60 hz 30 watts	120 v 60 hz 30 watts
Options Available	Carbon Filters (C) Power Cord (P) 220 v 50/60 hz	Carbon Filters (C) Power Cord (P) 220 v 50/60 hz	Carbon Filters (C) Power Cord (P) 220 v 50/60 hz	Carbon Filters (C) Power Cord (P) 220 v 50/60 hz

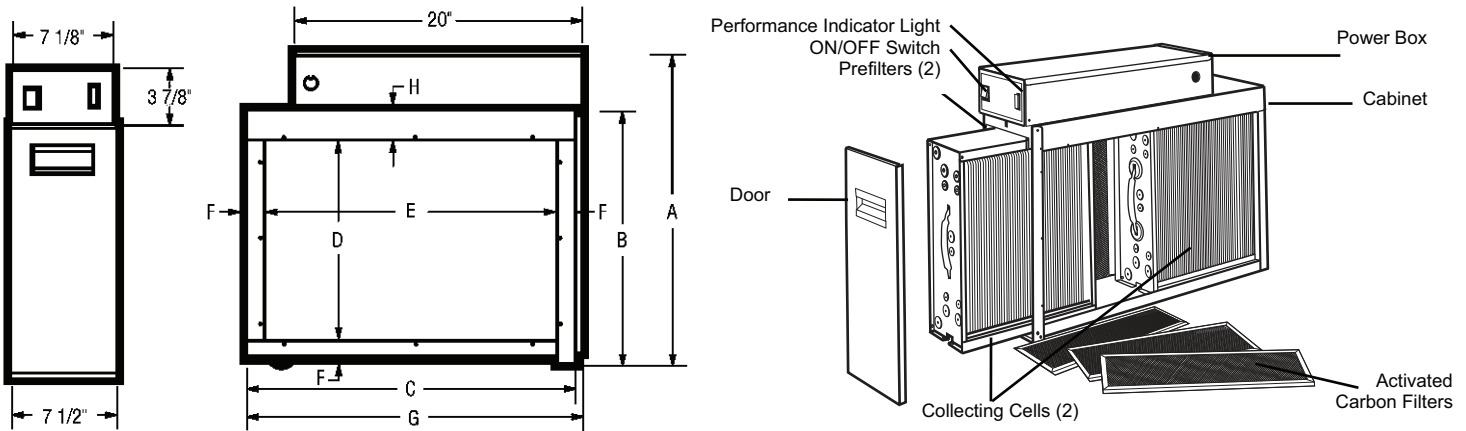

MODEL	DIMENSIONS — in (cm)							
	A	B	C	D	E	F	G	H
P102-12	21 (53.0)	17 (43.5)	23 1/4 (59.0)	13 1/8 (33.5)	20 3/4 (53.0)	1 1/4 (3.0)	23 3/4 (60.5)	2 3/8 (6.0)
P102-14A	21 (53.0)	17 (43.5)	26 (66.0)	13 5/8 (34.5)	24 (61.0)	1 (2.5)	26 1/2 (67.5)	2 1/8 (5.5)
P102-14B	25 7/8 (66.0)	22 (56.0)	21 1/4 (54.0)	18 (46.0)	18 3/4 (47.5)	1 1/4 (3.0)	21 3/4 (55.0)	2 3/8 (6.0)
P102-20	25 7/8 (66.0)	22 (56.0)	26 (66.0)	18 (46.0)	23 1/2 (59.5)	1 1/4 (3.0)	26 1/2 (67.5)	2 3/8 (6.0)

Manufacturer reserves the right to discontinue or change at any time, specifications or designs without notice or without incurring obligations. Performance of the Air Cleaners will depend on house plan design, duct design and heating/cooling equipment.

Air Cleaner Help Line Toll Free: 1-800-267-8305

